

# The Heparin-binding Domain of Extracellular Superoxide Dismutase Is Proteolytically Processed Intracellularly during Biosynthesis\*

(Received for publication, January 7, 1999, and in revised form, March 12, 1999)

Jan J. Enghild<sup>‡§</sup>, Ida B. Thøgersen<sup>‡</sup>, Tim D. Oury<sup>¶</sup>, Zuzana Valnickova<sup>‡</sup>, Peter Højrup<sup>||</sup>, and James D. Crapo<sup>\*\*</sup>

From the <sup>‡</sup>Department of Pathology, Duke University Medical Center, Durham, North Carolina 27710, the <sup>¶</sup>University of Pittsburgh Medical Center, Pittsburgh, Pennsylvania 15213, the <sup>||</sup>University of Odense, DK 5230 Odense, Denmark, and the <sup>\*\*</sup>National Jewish Medical and Research Center, Denver, Colorado 80206

Extracellular superoxide dismutase (EC-SOD) is the only known extracellular enzyme designed to scavenge the superoxide anion. The purified enzyme exists in two forms when visualized by reduced SDS-polyacrylamide gel electrophoresis: (i) intact EC-SOD (Trp<sup>1</sup>-Ala<sup>222</sup>) containing the C-terminal heparin-binding domain and (ii) cleaved EC-SOD (Trp<sup>1</sup>-Glu<sup>209</sup>) without the C-terminal heparin-binding domain. The proteolytic event(s) leading to proteolysis at Glu<sup>209</sup>-Arg<sup>210</sup> and removal of the heparin-binding domain are not known, but may represent an important regulatory mechanism. Removal of the heparin-binding domain affects both the affinity of EC-SOD for and its distribution to the extracellular matrix, in which it is secreted. During the purification of human EC-SOD, the intact/cleaved ratio remains constant, suggesting that proteolytic removal of the heparin-binding domain does not occur during purification (Oury, T. D., Crapo, J. D., Valnickova, Z., and Enghild, J. J. (1996) *Biochem. J.* 317, 51–57). This was supported by the finding that fresh mouse tissue contains both intact and cleaved EC-SOD. To study other possible mechanisms leading to the formation of cleaved EC-SOD, we examined biosynthesis in cultured rat L2 epithelial-like cells using a pulse-chase protocol. The results of these studies suggest that the heparin-binding domain is removed intracellularly just prior to secretion. In addition, the intact/cleaved EC-SOD ratio appears to be tissue-dependent, implying that the intracellular processing event is regulated in a tissue-specific manner. The existence of this intracellular processing pathway may thus represent a novel regulatory pathway for affecting the distribution and effect of EC-SOD.

Reactive oxygen species such as superoxide, hydrogen peroxide, and hydroxyl radical (O<sub>2</sub><sup>-</sup>, H<sub>2</sub>O<sub>2</sub>, and OH<sup>•</sup>, respectively) are important in several pathophysiologic events, including inflammation, mutagenesis, and aging. Leukocytes, when activated, produce large amounts of reactive oxygen species. Although this is beneficial in host defense, it may have detrimental effects on the cells and extracellular matrix in the vicinity of the response. Because reactive oxygen species damage cells and

the extracellular matrix, several defense mechanisms have evolved to protect against oxidant injury. Central to these defense mechanisms are the antioxidant enzymes. These include the superoxide dismutases, catalase, and glutathione peroxidase.

The superoxide dismutases (SODs)<sup>1</sup> (EC 1.15.1.1) catalyze the dismutation of two superoxide radicals into hydrogen peroxide and oxygen. These enzymes obey first-order reaction kinetics, and the forward rate constants are almost diffusion-limited (>10<sup>9</sup> M<sup>-1</sup> s<sup>-1</sup>) (1). This results in a steady-state concentration of superoxide in tissue that varies directly with the rate of superoxide generation and inversely with the tissue concentration of scavenging enzymes (2). The three isozymes of superoxide dismutase in mammals include Cu/Zn-SOD, Mn-SOD, and EC-SOD. EC-SOD is a heparin-binding multimer composed of disulfide-linked dimers (see Fig. 1) (3, 4). Similar to intracellular Cu/Zn-SOD, EC-SOD contains both copper and zinc (3). EC-SOD is the primary extracellular antioxidant enzyme and is highly expressed in the lungs of humans, where it is produced in the alveolar septa by type 2 epithelial cells (5, 6). In addition, the enzyme is highly expressed in blood vessels and airways (7–9). In arteries, EC-SOD constitutes up to 70% of the total SOD activity (9) and may play a pivotal role in regulating the bioavailability of nitric oxide in vessel walls, airways, and lung tissue. The reaction of nitric oxide with superoxide is diffusion-limited, allowing low levels of extracellular superoxide to interfere with the signaling of nitric oxide in smooth muscle relaxation and neurotransmission and in controlling inflammation. By scavenging extracellular superoxide, EC-SOD can enhance these nitric oxide responses.

The heparin-binding domains of two EC-SOD subunits are linked by a disulfide bond to form a cluster of 12 positively charged amino acid residues (Fig. 1) (4). These residues provide the basis for the electrostatic interactions with heparan sulfate, which anchors EC-SOD to specific regions of the extracellular matrix and on cell surfaces (6, 7, 9, 11). The affinity of purified EC-SOD can be divided in three classes (12, 13): EC-SOD with no affinity (type A), moderate affinity (type B), or high affinity (type C) for heparin (Fig. 2) (3). The heterogeneous heparin affinity is a result of proteolysis of the heparin-binding domain (13). Proteases such as trypsin specifically cleave the heparin-binding domain of native EC-SOD *in vitro*; however, the protease(s) responsible for this cleavage *in vivo* are unknown. Regulation of this proteolytic event may be an important control point in modulating EC-SOD activity in the extra-

\* This work was supported by National Institutes of Health Grants HL49542 (to J. J. E.) and HL31992 and HL42444 (to J. D. C.). The costs of publication of this article were defrayed in part by the payment of page charges. This article must therefore be hereby marked "advertisement" in accordance with 18 U.S.C. Section 1734 solely to indicate this fact.

§ To whom correspondence should be addressed: Pathology Dept., Duke University Medical Center, P. O. Box 3712, Durham, NC 27710. Tel.: 919-684-2872; Fax: 919-684-2920; E-mail: enghi001@mc.duke.edu.

<sup>1</sup> The abbreviations used are: SODs, superoxide dismutases; EC-SOD, extracellular superoxide dismutase; PAGE, polyacrylamide gel electrophoresis; HPLC, high pressure liquid chromatography.

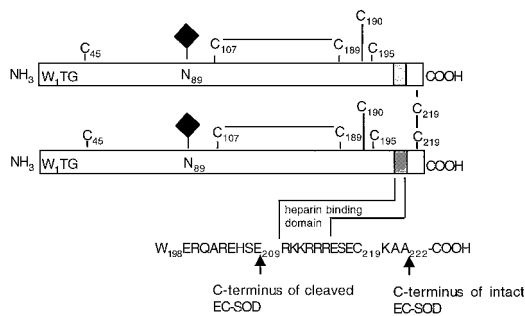

**FIG. 1. Schematic showing the structure of the EC-SOD dimer.** The N-terminal amino acid residues and the position of the single N-linked glycan at Asn<sup>89</sup> are indicated. The putative intrachain disulfide bridge between Cys<sup>107</sup> and Cys<sup>189</sup> or possible Cys<sup>190</sup> is shown based on the homology to Cu/Zn-SOD. We have experimentally confirmed the position of the interchain disulfide between Cys<sup>219</sup> residues in adjacent subunits (4). The determination of the proteolytic cleavage site within the heparin-binding domain is described under "Results." Amino acid residues are shown in single-letter code.

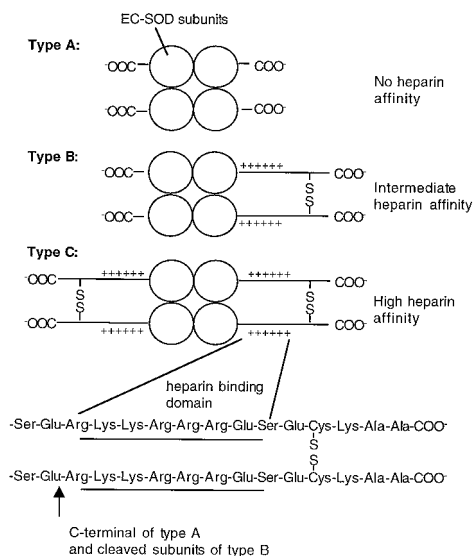

**FIG. 2. Modulation of EC-SOD heparin affinity.** EC-SOD is a tetramer composed of two disulfide-linked dimers (4). The heparin-binding domain contains six positively charged amino acids (Arg-Lys-Lys-Arg-Arg-Arg) and is located in the C terminus of each molecule as indicated (13). Truncation of the C-terminal region does not affect the noncovalent protein-protein interactions stabilizing the tetramer (4), but affects the heparin-binding properties significantly. Three forms of EC-SOD are thought to exist *in vivo*: type A, with all four C termini truncated and therefore no heparin affinity; type B, with partial C-terminal truncation and medium heparin affinity; and type C, with all four C-terminal domains intact and high heparin affinity (3). The existence of these variants suggests that the heparin affinity of EC-SOD is modulated by the degree of C-terminal proteolysis.

cellular matrix of tissues.

The number of physiologic and pathologic processes in which EC-SOD is found to be an important mediator continues to expand. This study shows that the C terminus of purified cleaved EC-SOD is Glu<sup>209</sup> and that the proteolytic conversion of intact EC-SOD is an intracellular process. This processing pathway may therefore represent a novel regulatory mechanism for controlling superoxide concentrations in tissues.

#### EXPERIMENTAL PROCEDURES

**Reagents**—ECL Western blotting detection reagents were from Amersham Pharmacia Biotech. RPMI 1640 medium, the RPMI 1640 medium select amine kit, phosphate-buffered saline, Earle's balanced salt solution, and penicillin/streptomycin were from Life Technologies, Inc. Epidermal growth factor, L-glutamine, and protamine were from Sigma. Rat lung L2 epithelial-like cells were obtained from American Type Culture Collection (Rockville, MD). Radiochemicals were from NEN

Life Science Products. EC-SOD was purified as described previously (4). EC-SOD was radioiodinated using lactoperoxidase-glucose oxidase (Bio-Rad) according to instructions provided by the manufacturer.

**Metabolic Labeling and Pulse-Chase Analysis**—Rat lung L2 epithelial-like cells were maintained in nutrient mixture F-12/Ham's medium (Life Technologies, Inc.) supplemented with 10% fetal bovine serum, L-glutamine (150 mg/500 ml), and 1% penicillin/streptomycin (100 units/ml medium) in 5% CO<sub>2</sub>. For standard biosynthetic radiolabeling, cells were grown in 50-mm tissue culture plates until 80% confluent. The cells were then washed twice with Earle's balanced salt solution and incubated for 30 min in Met-deficient nutrient mixture F-12 without fetal bovine serum. The cells were incubated for 5 min in medium containing [<sup>35</sup>S]Met (pulse period). The cells were promptly rinsed twice with serum-free nutrient mixture F-12 and incubated with unlabeled complete medium for various periods of time (chase periods).

**Lysis and Immunoprecipitation**—The conditioned medium was collected and frozen. Cell lysates were prepared by three rapid freeze-thaw cycles in high salt buffer containing 0.5% Triton X-100 and a proteinase inhibitor mixture. Prior to immunoprecipitation, the lysates and conditioned medium were cleared by the addition of a preimmune serum followed by the addition of protein G-Sepharose 4FF (Amersham Pharmacia Biotech). The supernatants were incubated overnight with the relevant specific antiserum. The next day, protein G-Sepharose 4FF was added, and immunoprecipitates were collected by gentle centrifugation. The immunoprecipitates were then washed several times, and bound proteins were released from the protein G-Sepharose 4FF by boiling in SDS sample buffer or by 100 mM glycine HCl (pH 2.7) before SDS-PAGE.

**Proteolysis of EC-SOD following Secretion**—Rat L2 epithelial-like cells were cultured as described above in 50-mm tissue culture plates. When the culture was ~80% confluent, the cells were washed twice with Earle's balanced salt solution, and serum-free medium (nutrient mixture F-12/Ham's medium) containing protamine (50 μg/ml) and [<sup>125</sup>I]-labeled human EC-SOD (7 × 10<sup>6</sup> cpm) was added. The cells were maintained in a water-jacketed CO<sub>2</sub> incubator at 37 °C and remained viable for >48 h. Aliquots of the medium were removed at timed intervals and analyzed by SDS-PAGE.

**Protein Sequencing and Amino Acid Analysis**—Proteins and peptides were analyzed by automated Edman degradation in an Applied Biosystems 477A sequencer with on-line phenylthiohydantoin analysis using an Applied Biosystems 120A HPLC system. Protein concentrations were determined by amino acid analysis (15). The sample was hydrolyzed in 6 M HCl for 24 h, and the composition was determined in a Beckman Model 6300 amino acid analyzer using the sodium citrate buffer system provided by the manufacturer. Both instruments were operated as recommended in the user bulletins distributed by the manufacturer.

**Radiosequence Analysis**—These analyses were performed as described previously (16, 17). Briefly, after immunoprecipitation and SDS-PAGE, the <sup>35</sup>S-labeled proteins were electrotransferred to Immobilon membranes (18). The proteins were identified by autoradiography, and bands of interest were excised and analyzed by automated Edman degradation. The anilinothiazolinone-derivatives released after each cycle were collected and counted for <sup>35</sup>S radioactivity. In the experiments destined for radiosequence analysis, the metabolic labeling was performed using appropriate radioactive amino acids expected within the first 20 N-terminal residues of the mature proteins. Subsequent radiosequence analysis of the bands and release of radioactive anilinothiazolinone-derivatives in the anticipated cycle of Edman degradation provided unequivocal identification of the protein band.

**C-terminal Determination**—Approximately 50 μg of purified human EC-SOD was dissolved in 50 μl of 100 mM NH<sub>4</sub>HCO<sub>3</sub> (pH 7.8) and digested overnight with 0.5 units of endoglycosidase F at 37 °C. A sample was withdrawn for mass analysis to confirm that the deglycosylation reaction was completed. The remainder was digested with 0.2 μg of chymotrypsin for 4 h at 37 °C before separation by reverse-phase HPLC. All resulting peaks were analyzed by mass spectrometry.

**Mass Spectrometry**—A REFLEX matrix-assisted laser desorption ionization time-of-flight mass spectrometer (Bruker Analytik GmbH, Bremen, Germany) was used for analysis of the deglycosylated protein and of peptides in positive linear mode. Ion acceleration was 22 kV. The analyte solution, 2% trifluoroacetic acid, and matrix solution (15–20 g/liter of α-cyano-4-hydroxycinnamic acid in 70% acetonitrile) were mixed in equal proportions on the target and dried. The dry crystalline deposit was carefully rinsed with a small volume of 0.1% trifluoroacetic acid. The spectra were externally calibrated.

**Polyacrylamide Gel Electrophoresis**—The supernatants from SDS-treated immunoprecipitates were recovered by centrifugation and ana-

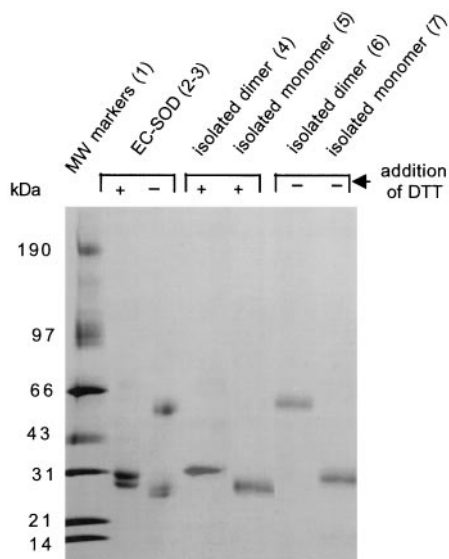

**FIG. 3. SDS-PAGE analysis of purified human EC-SOD.** Purified EC-SOD was analyzed by unreduced and reduced SDS-PAGE (lanes 2 and 3, respectively). The unreduced dimer and monomer were recovered and analyzed again both with (+) and without (-) reduction with dithiothreitol (DTT). The N termini of all bands were determined by N-terminal sequence analysis. This analysis revealed that all bands contained the same N-terminal sequence, indicating that the differences in size were secondary to C-terminal truncation. Dimeric EC-SOD is composed exclusively of intact EC-SOD monomers containing the C-terminal heparin-binding domain. Monomeric EC-SOD is composed exclusively of cleaved EC-SOD lacking the C-terminal heparin-binding domain.

lyzed by SDS-PAGE with 5–15% gradient gels (19). The gels were stained, destained, dried, and subjected to imaging on a PhosphorImager (Molecular Dynamics 410A). Immunoprecipitates for radiosequence analysis were transferred to polyvinylidene difluoride membranes. The polyvinylidene difluoride membranes were then dried and exposed directly to x-ray film overnight at  $-70^{\circ}\text{C}$ .

**Immunoblotting**—Membranes were developed using the ECL Western blotting kit from Amersham Pharmacia Biotech. Briefly, following transfer to polyvinylidene difluoride membranes, the membranes were blocked for 1 h in 20 mM Tris-Cl and 137 mM NaCl (pH 7.6) containing 0.1% Tween (Tris-buffered saline/Tween buffer) and 5% of the supplied blocking reagent. The membrane was washed in Tris-buffered saline/Tween buffer before the primary antibody was added (1:2000 dilution). Following a 1-h incubation, the membrane was washed in Tris-buffered saline/Tween buffer, and the horseradish peroxidase-labeled secondary antibody was added (1:20,000 dilution). The membranes were incubated for 1 h, washed with Tris-buffered saline/Tween buffer, and developed using the supplied reagent.

**Perfusion of Mice**—Mice were anesthetized using 5 mg of sodium pentobarbital (Nembutal). The perfusion was performed after deep anesthesia, but prior to death, via the left ventricle of the heart using phosphate-buffered saline containing 0.5%  $\text{NaNO}_2$ , 10 units/ml heparin, and a protease inhibitor mixture composed of 0.1 mM 1,10-phenanthroline, 2 mM phenylmethanesulfonyl fluoride, and 0.02 mM E-64 (20). Following perfusion, the organs were removed and homogenized (Virtis Tempest) in 50 mM HEPES and 100 mM NaCl (pH 7.4). The supernatants were analyzed by SDS-PAGE and immunoblotting.

## RESULTS

**Analysis of the 30-kDa Human EC-SOD Doublet by SDS-PAGE**—Purified EC-SOD migrates on unreduced SDS-PAGE as a 60- and 30-kDa band. Following reduction, the protein migrates as a tightly spaced  $\sim 30$ -kDa doublet (Fig. 3, lane 2). The origin of these bands was investigated by two dimensional SDS-PAGE. Purified EC-SOD was first analyzed without reduction (Fig. 3, lane 3), and the bands were transferred to a CD-membrane<sup>TM</sup> (Millipore Corp.). The 60-kDa dimer and the 30-kDa monomer bands were extracted and separately reanalyzed by reduced SDS-PAGE (Fig. 3, lanes 4 and 5). These experiments show that the unreduced 60-kDa EC-SOD band

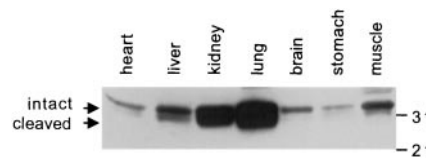

**FIG. 4. SDS-PAGE followed by immunoblotting of perfused mouse tissue.** Anesthetized mice were perfused with a buffer containing a protease inhibitor mixture to remove all blood and to prevent adventitious proteolysis. The organs were removed and homogenized on ice in the presence of a protease inhibitor mixture (1,10-phenanthroline, 3,4-dichloroisocoumarin, and E-64 (20)). The homogenized organs were centrifuged briefly, and portions of the supernatants were subjected to reduced SDS-PAGE followed by immunoblotting using anti-mouse EC-SOD antibodies. These experiments were performed within minutes after the animals had been perfused. An example of the immunoblotting is shown. It is apparent that the heart, brain, stomach, and muscle contain mainly intact EC-SOD. In contrast, the kidneys and lungs appear to contain equal amounts of both intact and cleaved EC-SOD. This suggests that the processing event leading to cleaved EC-SOD is regulated differently in various tissues.

was composed exclusively of the top band, representing intact EC-SOD. The unreduced 30-kDa EC-SOD band was composed exclusively of the lower band, representing cleaved EC-SOD. Deglycosylation experiments have previously shown that the difference in size of the reduced  $\sim 30$ -kDa doublet is not due to carbohydrate heterogeneity (4). Moreover, N-terminal protein sequence analysis following transfer to polyvinylidene difluoride revealed that the N termini were intact in both bands (data not shown). This suggests that the top band of the reduced  $\sim 30$ -kDa EC-SOD doublet represents intact EC-SOD and that the bottom band represents C-terminally cleaved EC-SOD.

**Determination of the C-terminal Cleavage Site of Purified Human EC-SOD**—Mass spectrometric analysis of EC-SOD after removal of the  $\text{Asn}^{89}$  carbohydrate moiety by *N*-glycosidase F showed the main component as a rather broad peak with a molecular mass of  $22.530 \pm 40$  Da. This mass most closely corresponded to  $\text{Trp}^1\text{-Glu}^{209}$  (22.559 Da). Due to the width of the peak, termination at one of the adjacent residues could not be excluded. As the region around  $\text{Glu}^{209}$  contains several basic and acidic residues, the reduced and carboxamidomethylated EC-SOD was digested with chymotrypsin. Analysis of the digest by reverse-phase HPLC and mass spectrometry revealed a peptide corresponding to  $\text{Glu}^{201}\text{-Glu}^{209}$  (experimental mass of 1141.26 Da; theoretical mass of 1141.17 Da). These results confirm that the C terminus of cleaved EC-SOD is  $\text{Glu}^{209}$ .

**EC-SOD Exists in Tissues in Both Its Intact and Cleaved Forms**—As described above, reduced SDS-PAGE can be used as an assay to identify intact and C-terminally cleaved EC-SOD. Mice were perfused, and the tissues were homogenized in a buffer containing a protease inhibitor mixture. The supernatants were analyzed by reduced SDS-PAGE within 15 min of perfusion. Following electrophoresis, EC-SOD was visualized by immunoblotting (Fig. 4). The results show that the heart, liver, brain, stomach, and skeletal muscle appear to contain mainly intact EC-SOD, whereas the kidneys and lungs contain equal amounts of cleaved and intact EC-SOD. This suggests that the processing event leading to monomeric EC-SOD is regulated differently in various tissues.

**Biosynthesis of EC-SOD**—Intracellular processing of EC-SOD was studied in cultured rat lung L2 epithelial-like cells. The biosynthesis of EC-SOD was explored using a pulse-chase protocol followed by immunoprecipitation, SDS-PAGE, and radiosequence analysis (Figs. 5 and 6). Radiosequence analysis was done to verify the identity and integrity of the immunoprecipitated bands (Fig. 6). Both the intact and cleaved bands of EC-SOD were found to be made by the cells. Radiosequence analysis confirmed that both  $\sim 30$ -kDa bands were EC-SOD

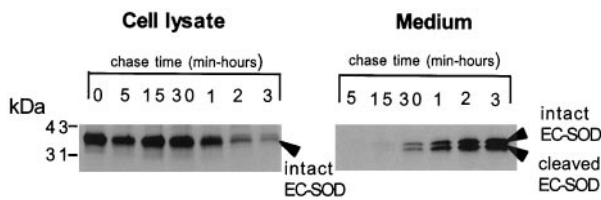

FIG. 5. **Biosynthesis of EC-SOD in rat L2 cells.** The cells were metabolically labeled with [<sup>35</sup>S]Met-supplemented medium for 15 min and chased for the indicated times in radiolabel-free medium. EC-SOD was immunoprecipitated using an anti-mouse EC-SOD IgG fraction and analyzed by reduced SDS-PAGE and autoradiography. EC-SOD appeared in the medium 30 min after the onset of biosynthesis. Note that approximately one-half of the secreted EC-SOD was cleaved. Moreover, EC-SOD appears to be cleaved late in the biosynthetic pathway, most likely in secretory vesicles, since cleaved EC-SOD was not detected intracellularly, but was detected in the cell culture medium 30 min after the onset of biosynthesis.

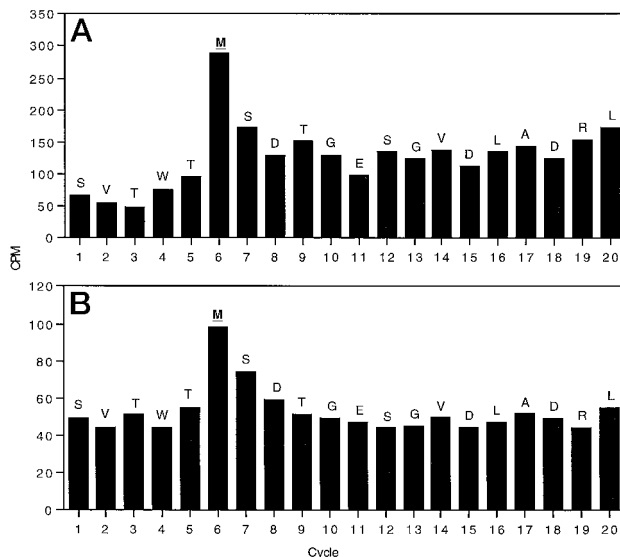

FIG. 6. **N-terminal radiosequence analysis.** Biosynthetically radiolabeled EC-SOD immunoprecipitates from the medium of rat L2 cells were subjected to radiosequence analysis. The cells were pulse-labeled with [<sup>35</sup>S]Met and subjected to immunoprecipitation, electrophoresis, autoradiography, and radiosequencing. The vertical bars represent the level of <sup>35</sup>S radioactivity released during each cycle of Edman degradation. Both intact EC-SOD (A) and cleaved EC-SOD (B) were analyzed. The N-terminal protein sequence of mature EC-SOD is indicated above each vertical bar to facilitate interpretation. The results confirm that the immunoprecipitated bands are EC-SOD and that the N termini are intact. Significantly, the difference in migration during SDS-PAGE is caused by C-terminal processing.

and further demonstrated that the difference between the two bands is due to processing of the C terminus since the N terminus is intact and identical for both protein bands (Fig. 6).

The data suggest that a fraction of EC-SOD is cleaved inside the cells, resulting in the secretion of both cleaved and intact EC-SOD. In this cell line, the ratio between the secreted intact (top band) and cleaved (lower band) EC-SOD appeared to be 1:1, which is the same ratio observed in whole lung homogenates (Fig. 4). This ratio between intact and cleaved EC-SOD in the cell culture medium remained constant during the duration of the experiment. If EC-SOD were secreted exclusively as intact subunits and then cleaved in the medium, we would expect to see an accumulation of cleaved EC-SOD over time. To evaluate further where the cleavage of EC-SOD occurred, purified iodinated EC-SOD was added to the rat lung L2 epithelial-like cells in serum-free medium containing protamine. Protamine was added to prevent EC-SOD from binding heparin, which has been previously shown to protect against prote-

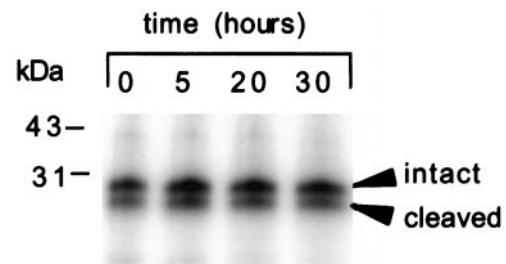

FIG. 7. **Proteolysis of the EC-SOD heparin-binding domain does not proceed in the cell culture medium or on the cell surface.** To examine if proteolysis of the EC-SOD heparin-binding domain occurred just after secretion, purified <sup>125</sup>I-labeled human EC-SOD was added to the medium of cultured rat L2 epithelial-like cells. Both protease inhibitors and heparin may reduce proteolysis of the EC-SOD heparin-binding domain and thus influence the outcome of the experiment. The cells were consequently maintained in serum-free medium to eliminate the protease inhibitors from the serum, and protamine was added to bind residual heparin. The cells were maintained in a water-jacketed CO<sub>2</sub> incubator at 37 °C and remained viable for >48 h. Aliquots of the medium were removed as indicated and analyzed by SDS-PAGE. The relative intensity of the intact and cleaved EC-SOD bands in this and similar experiments suggested that the proteolysis did not progress extracellular in the medium or on the cell surface. This supports the conclusion that the observed proteolysis of EC-SOD is an intracellular event.

olysis of the heparin-binding domain (21). Samples were removed at timed intervals and analyzed by reduced SDS-PAGE (Fig. 7). In these experiments, no additional proteolysis of EC-SOD was observed even after 30 h of incubation, supporting the notion that EC-SOD proteolysis of EC-SOD occurs inside the cell.

These studies indicate that the C-terminal cleavage occurs late during the biosynthesis, just before secretion. This is a characteristic of processing events, which take place in secretory vesicles. For example, free  $\alpha_1$ -microglobulin and free bikunin are not readily detected inside the cell because the processing takes place just prior to secretion (16, 22, 23). This is similar to EC-SOD and provided a rationale to support our conclusion that the proteolytic processing of the heparin-binding domain is an intracellular event.

## DISCUSSION

Steady-state concentrations of the superoxide anion are directly proportional to the rate of production and inversely proportional to the concentration of scavenging enzymes such as the superoxide dismutases. EC-SOD is the only enzymatic scavenger of superoxide in the extracellular matrices of tissues. Thus, alterations in EC-SOD activity will have important consequences on the steady-state concentrations of superoxide in the extracellular spaces of tissues. Therefore, if there is increased synthesis of EC-SOD, there will be a decrease in the steady state of superoxide in the matrix in which EC-SOD is secreted. Conversely, if there is proteolytic removal of the heparin-binding domain, EC-SOD will lose its affinity for the extracellular matrix and diffuse out of the tissue. This will result in decreased EC-SOD activity and lead to an increase in the steady-state concentration of superoxide in this domain.

The effect of C-terminal truncation will depend on the tissue in which it is residing. For example, in the lung, this may allow EC-SOD to diffuse from the alveolar septa into the alveolar fluid, where it can then prevent superoxide-mediated damage to surfactant. This study has examined the proteolytic processing of the heparin domain of EC-SOD and suggests that proteolytic regulation of the heparin-binding domain is an intracellular, tissue-specific event.

*EC-SOD Is Found in Tissues Both in the Intact and Cleaved Forms*—Purified EC-SOD migrates as a 60- and 30-kDa band

on unreduced SDS-PAGE. The 30-kDa band is produced by proteolysis of the Glu<sup>209</sup>-Arg<sup>210</sup> peptide bond, which results in dissociation of the disulfide-bound 60-kDa dimer. We initially investigated if this cleavage event was the result of fortuitous proteolysis during the purification of EC-SOD. However, rigorous attempts to control the proteolysis were unsuccessful. Since the level of cleaved EC-SOD remained the same regardless of the steps taken to prevent proteolysis, we hypothesized that cleaved EC-SOD may be present within tissues *in vivo*.

Tissues from mice that had been perfused with a protease inhibitor-containing buffer were examined for evidence of cleaved EC-SOD. This perfusion procedure removed all blood and eliminated interference from cleaved EC-SOD present in the blood. The homogenized tissue supernatants were analyzed by SDS-PAGE within minutes of the perfusion. These analyses show that EC-SOD is present in both the cleaved and uncleaved forms in the matrices of tissues *in vivo*. Moreover, the results suggest that the proteolytic processing is an *in vivo* event and not an artifact that occurs during the purification of the enzyme. Evaluation of the EC-SOD composition in different organs reveals that the ratio between intact and cleaved EC-SOD varies considerably between different tissues. The heart shows almost exclusively intact EC-SOD, whereas lung tissue contains equal amounts of the two forms, suggesting that the regulation of EC-SOD proteolysis is tissue-specific.

**Biosynthesis Data Indicate That EC-SOD Is Cleaved Intracellularly**—The biosynthesis of EC-SOD was examined by a pulse-chase metabolic labeling protocol that has been previously employed to analyze intracellular processing events (16, 17). In this case, cultured rat lung L2 epithelial-like cells were maintained in multiple-tissue culture plates and briefly labeled using [<sup>35</sup>S]Met. After the pulse, each tissue culture plate was chased with nonradioactive cell culture medium for timed intervals. Following the completion of the chase periods, EC-SOD was immunoprecipitated and subjected to SDS-PAGE and Western blotting. The protein bands were visualized by autoradiography, and relevant bands were analyzed by radiosequencing. This allowed us to confirm both the identity and the integrity of immunoprecipitated bands. These experiments demonstrate that cleaved EC-SOD is present in the cell culture medium immediately upon secretion. Cleaved EC-SOD was not observed in the cell lysate, suggesting that the proteolytic event took place late in the biosynthesis pathway, most likely in the secretory vesicles or possibly in the Golgi apparatus. The cleaved/intact EC-SOD ratio in the medium remained constant for the duration of the experiment.

To confirm that the processing event occurred before secretion, purified <sup>125</sup>I-labeled EC-SOD was added to the medium of rat lung L2 epithelial-like cells cultured in serum-free medium. When EC-SOD is bound to heparin, the proteolysis of the heparin domain of EC-SOD is greatly diminished (21). As a consequence of this, the heparin antagonist protamine was added to the cell culture medium to bind residual heparin and to ensure that the <sup>125</sup>I-labeled EC-SOD heparin-binding domain was accessible for proteolysis. The lack of proteolysis after 30 h of incubation supports the conclusion that the processing of the EC-SOD heparin-binding domain is an intracellular event.

Based on the analysis of recombinant EC-SOD mutants with altered C termini, it has been suggested that the heparin-binding domain is cleaved by an endoprotease and further

trimmed by a carboxypeptidase (13). Considering this scenario and that we have now shown that the C terminus of cleaved EC-SOD is Glu<sup>209</sup> and that the initial cleavage site is intracellular, two possibilities seem likely: (i) the processing of EC-SOD is a one-step mechanism accomplished by a single intracellular endoproteolytic event cleaving the Glu<sup>209</sup>-Arg<sup>210</sup> peptide bond, or alternatively, (ii) two proteases are involved. In the latter case, the initial intracellular endoproteolytic event is further toward the C terminus, and a carboxypeptidase specific for basic amino acid residues then trims the remaining basic amino acid residues to Glu<sup>209</sup>. This trimming could be intra- or extracellular. If the processing is a one-step mechanism cleaving at Glu<sup>209</sup>, the specificity of the processing enzyme would represent the "opposite" of most other processing proteases, which cleave at the C terminus of (di)basic residues (10, 14). This suggests that the EC-SOD processing is performed by a novel enzyme. However, at this point, it is not clear which of the proposed mechanisms is involved during the maturation of EC-SOD.

Our results show that the proteolysis of EC-SOD is an intracellular process that is regulated differently in distinct tissues. The consequence of the proteolytic event is the removal of the EC-SOD heparin-binding domain and loss of heparin affinity. The cleaved EC-SOD subunit has no affinity for heparan sulfate proteoglycans expressed on the cell membrane and may thus diffuse into the surrounding tissue and fluids. In contrast, the heparin-binding intact EC-SOD is immobilized on cell surfaces and extracellular matrices where it is secreted. Thus, tissue-specific control of EC-SOD proteolytic processing allows for better regulation of the EC-SOD concentration, and thus the extracellular superoxide concentration, in specific extracellular domains.

#### REFERENCES

- Forman, H. J., and Fridovich, I. (1973) *Arch. Biochem. Biophys.* **158**, 396–400
- Fridovich, I. (1976) in *Free Radicals in Biology* (Pryor, W. A., ed) Vol. 1, 1st Ed., pp. 239–277, Academic Press, New York
- Marklund, S. L. (1982) *Proc. Natl. Acad. Sci. U. S. A.* **79**, 7634–7638
- Oury, T. D., Crapo, J. D., Valnickova, Z., and Enghild, J. J. (1996) *Biochem. J.* **317**, 51–57
- Su, W. Y., Folz, R., Chen, J. S., Crapo, J. D., and Chang, L.-Y. (1997) *Am. J. Respir. Cell Mol. Biol.* **16**, 162–170
- Folz, R. J., Guan, J. Z., Seldin, M. F., Oury, T. D., Enghild, J. J., and Crapo, J. D. (1997) *Am. J. Respir. Cell Mol. Biol.* **17**, 393–403
- Oury, T. D., Chang, L.-Y., Marklund, S. L., Day, B. J., and Crapo, J. D. (1994) *Lab. Invest.* **70**, 889–898
- Stralin, P., Karlsson, K., Johansson, B. O., and Marklund, S. L. (1995) *Arterioscler. Thromb. Vasc. Biol.* **15**, 2032–2036
- Oury, T. D., Day, B. J., and Crapo, J. D. (1996) *Free Radical Biol. Med.* **20**, 957–965
- Nakayama, K. (1997) *Biochem. J.* **327**, 625–635
- Oury, T. D., Chang, L.-Y., Marklund, S. L., and Crapo, J. D. (1993) *Am. Rev. Respir. Dis.* **147**, A444 (abstr.)
- Adachi, T., and Marklund, S. L. (1989) *J. Biol. Chem.* **264**, 8537–8541
- Sandstrom, J., Carlsson, L., Marklund, S. L., and Edlund, T. (1992) *J. Biol. Chem.* **267**, 18205–18209
- Seidah, N. G., and Chretien, M. (1997) *Curr. Opin. Biotechnol.* **8**, 602–607
- Ozols, J. (1990) *Methods Enzymol.* **182**, 587–601
- Thøgersen, I. B., and Enghild, J. J. (1995) *J. Biol. Chem.* **270**, 18700–18709
- Salvesen, G., and Enghild, J. J. (1990) *Biochemistry* **29**, 5304–5308
- Matsudaira, P. (1987) *J. Biol. Chem.* **262**, 10035–10038
- Bury, A. F. (1981) *J. Chromatogr.* **213**, 491–500
- Salvesen, G., and Nagase, H. (1989) in *Proteolytic Enzymes: A Practical Approach* (Beynon, R. J., and Bond, J. S., eds) 1st Ed., pp. 83–104, IRL Press, New York
- Karlsson, K., Edlund, A., Sandstrom, J., and Marklund, S. L. (1993) *Biochem. J.* **290**, 623–626
- Sjöberg, E. M., and Fries, E. (1992) *Arch. Biochem. Biophys.* **295**, 217–222
- Bratt, T., Olsson, H., Sjöberg, E. M., Jergil, B., and Åkerström, B. (1993) *Biochim. Biophys. Acta* **1157**, 147–154